

## G97045-46 • Market Loft with Extension Kit Assembly Instructions

**NOTE: These assembly instructions are for the Market Loft with the Extension Kit. Extension Kit Hardware is located in Box 7.**

**Maximum Weight Limit:** 1000 lbs.  
**For ages:** 3+

**Congratulations** on your purchase of our Market Loft. Prior to assembly, check all your parts to ensure they are free from defect or damage.

A few notes on safety and construction before you begin:

- Adult assembly required. Loft assembly requires two people.
- Never leave children unattended on or near loft.
- Do not place a loft near a window or furniture or other items that will encourage children to climb out of loft.
- Do not position loft near low-hanging items. Ensure adequate clearance is allowed for between ceiling and top of loft.
- Do not place objects inside loft platform or landing that will encourage children to climb over sides.
- Railing must be less than 3½" away from the wall of your room or stationary objects, or more than 9". Anything in between could be an entrapment hazard.
- For indoor use only.

**Customer Service:** For questions regarding this product, or to receive replacement or missing parts, contact Customer Service at (800) 524-3555. Please have the model number and part number(s) located in this Assembly Instruction sheet available for reference.

**Maintenance:** Periodically check to ensure all screws and bolts are tightened and properly fastened. If any parts are cracked or broken, please call us for a replacement. Do not use if any parts are damaged.

**Care Instructions:** To clean the wooden parts of your loft, use mild soap and water on a damp cloth. Do not use window cleaners or cleaning abrasives as they will scratch the surface and could damage the protective coating.

To clean the carpeted parts of your loft, vacuum, then apply standard carpet shampoo if necessary. Your loft stairs and platform have a polypropylene carpet and most spills should clean up with gentle soap and water. You may also use a steam cleaner on your carpet. Remember, not all carpet shampoos are designed alike. Therefore, it is recommended that you try a small spot prior cleaning a larger area.

### **▲ WARNING**

Small parts and sharp points may be present prior to assembly.

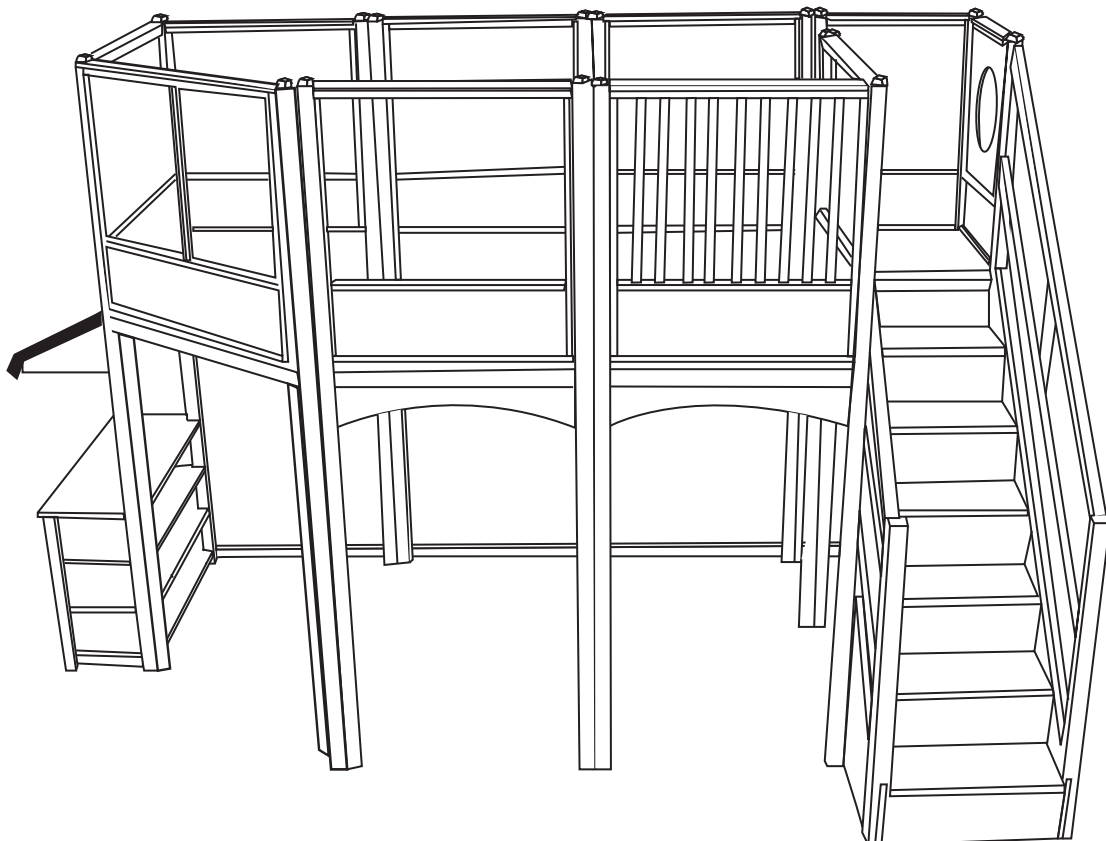

## Hardware and Parts

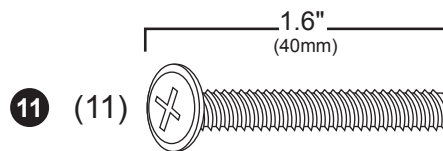
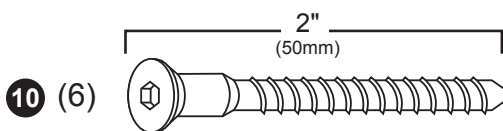
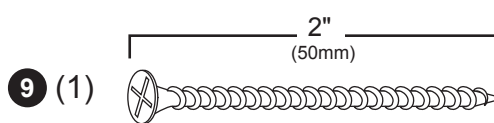
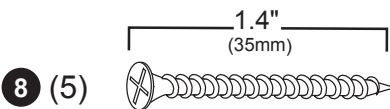
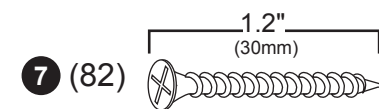
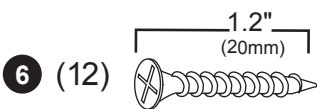
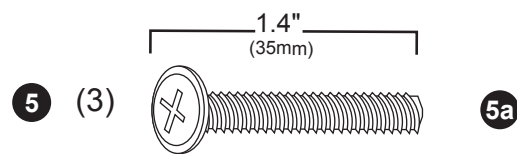
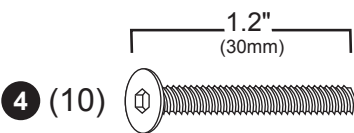
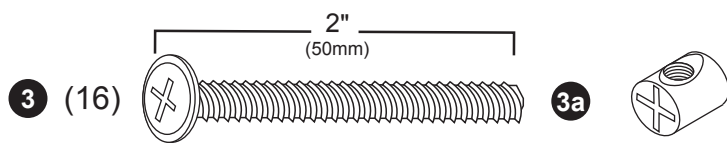
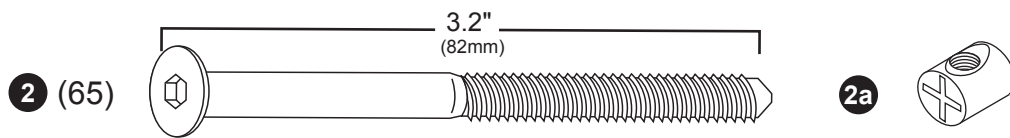
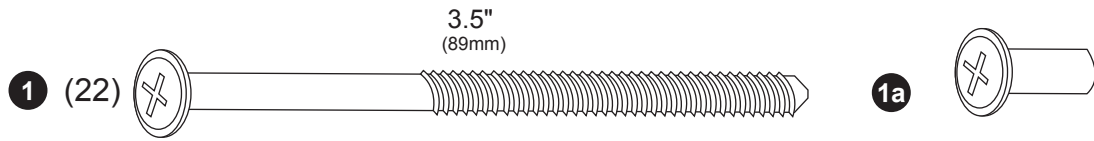

### Tools Included

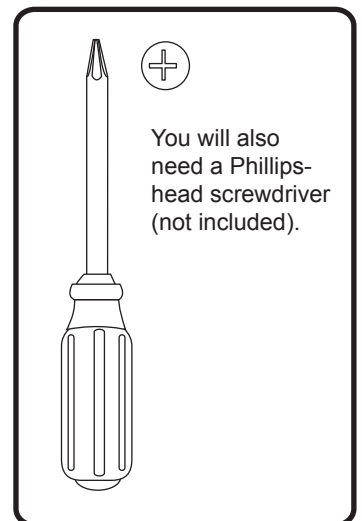
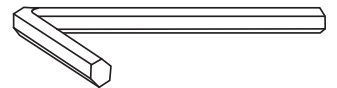

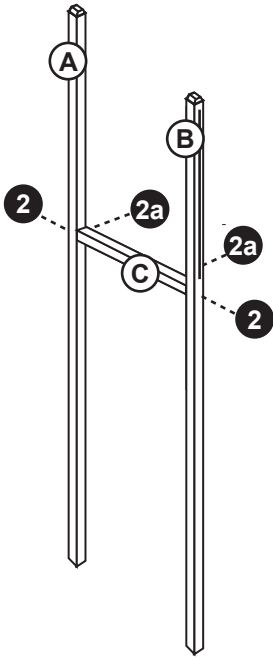

Step 1

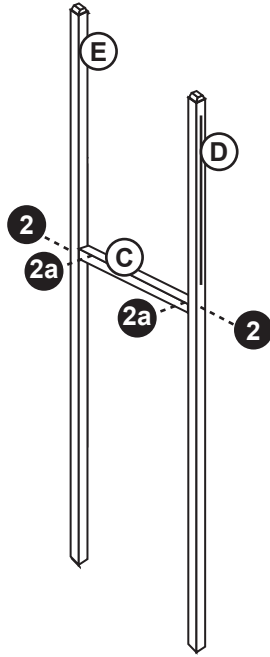

Step 2

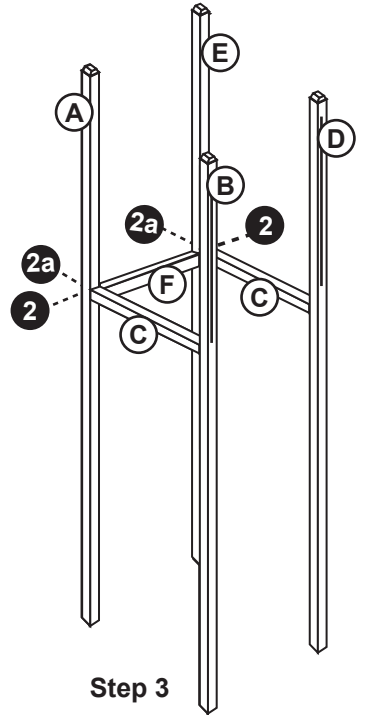

Step 3

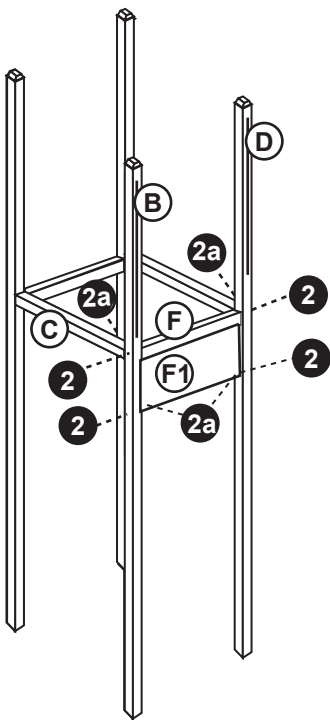

Step 4

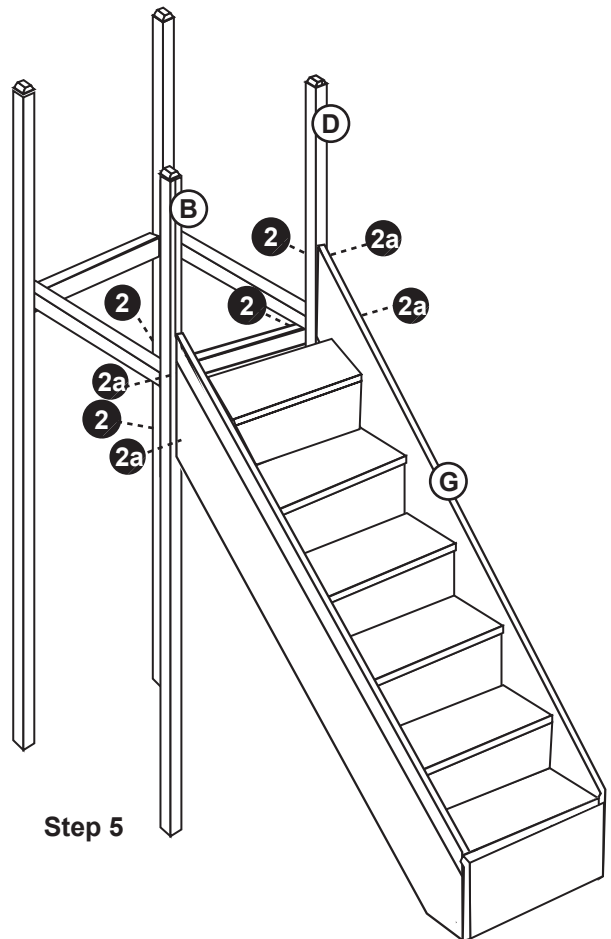

Step 5

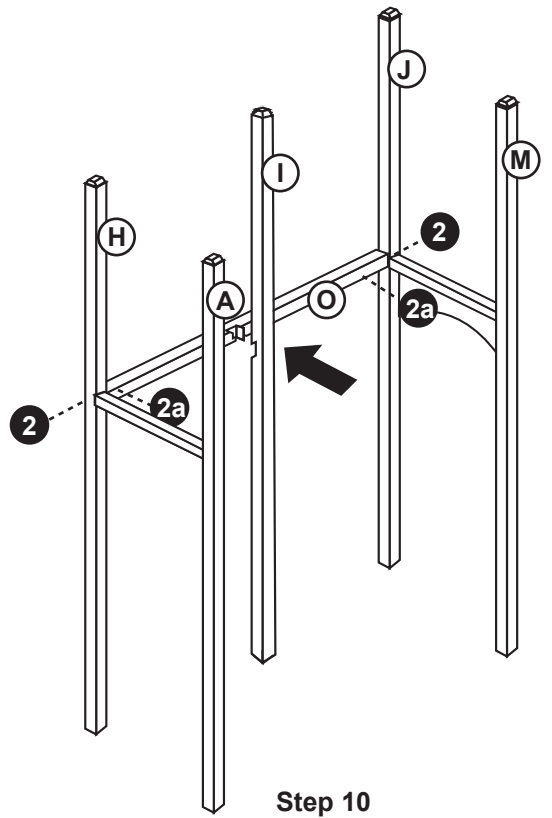
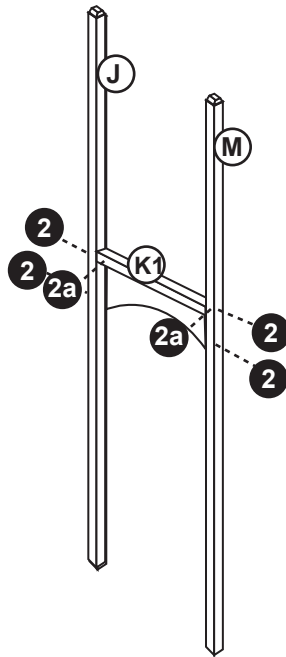
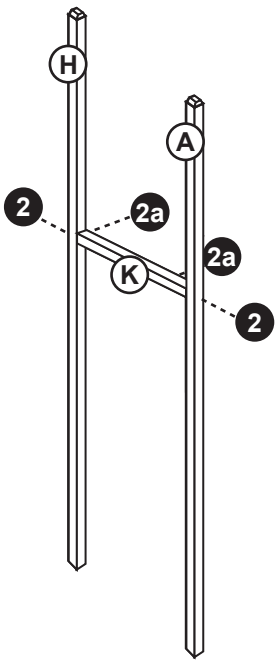
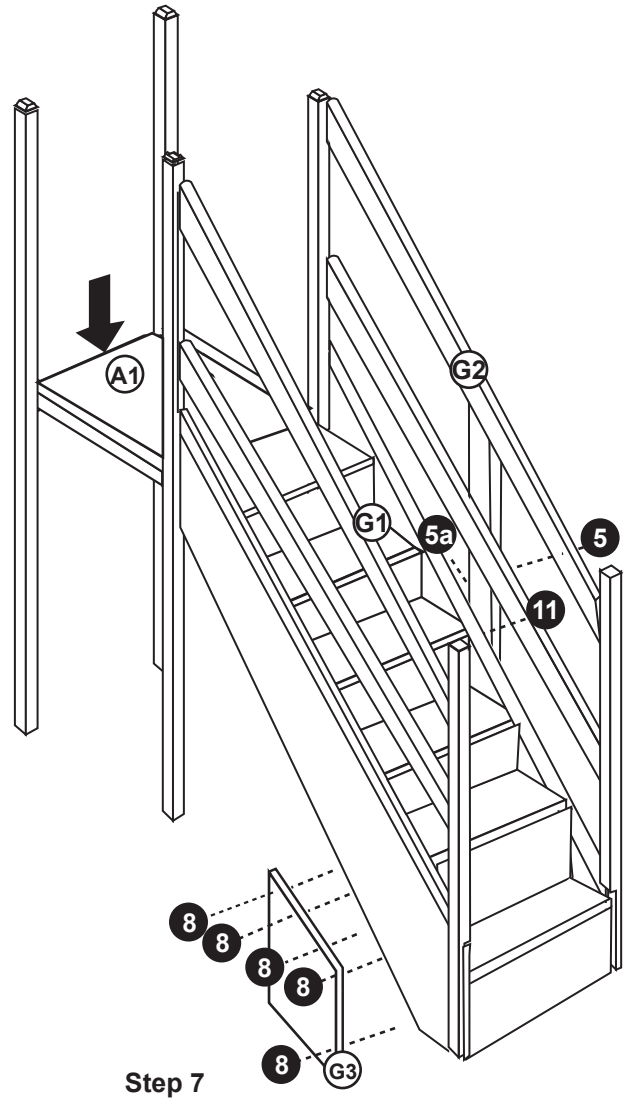
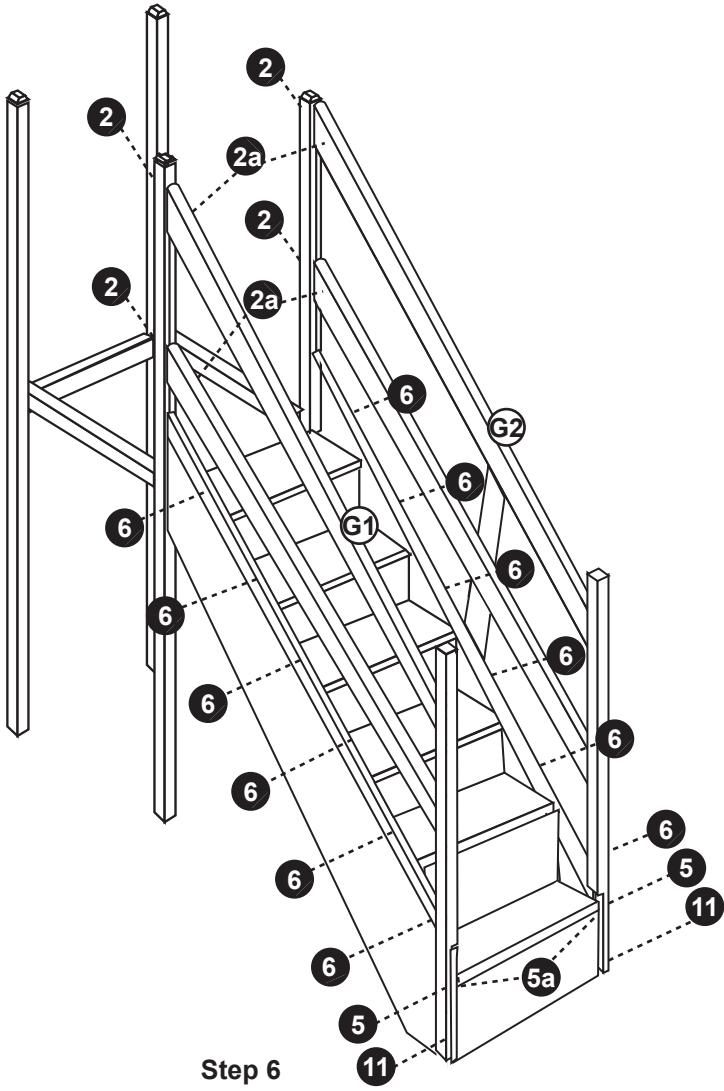

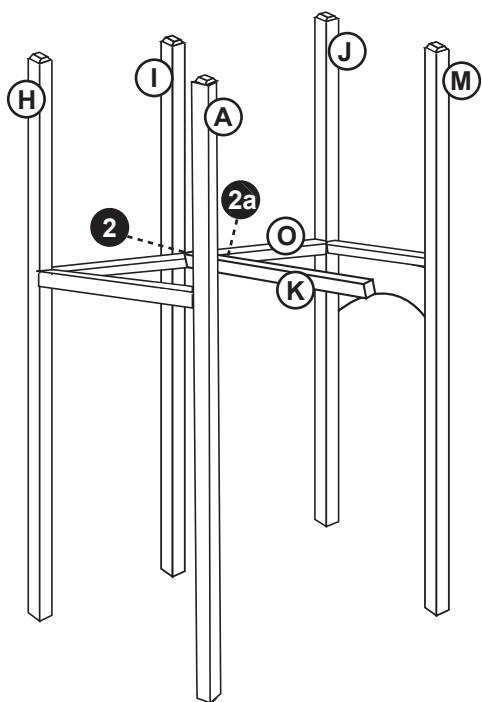

Step 11

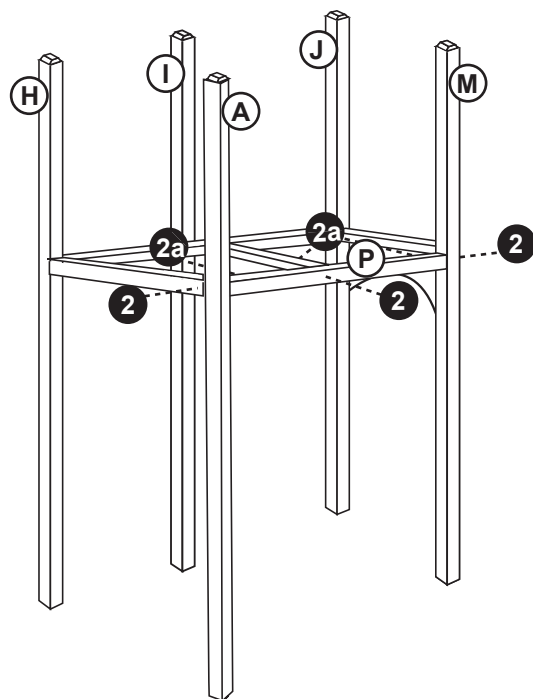

Step 12

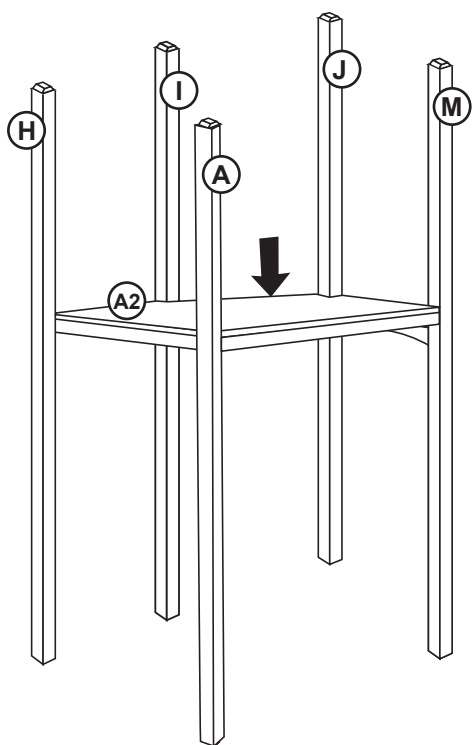

Step 13

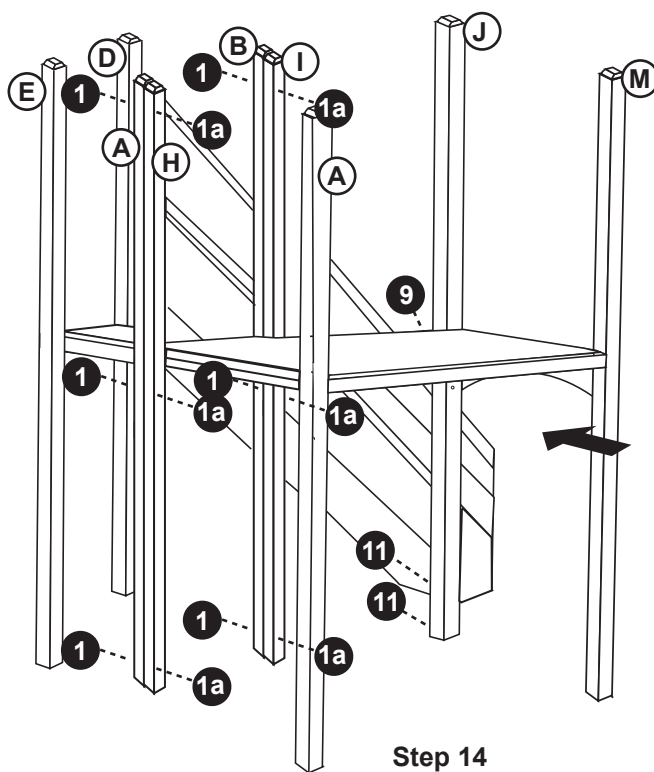

Step 14

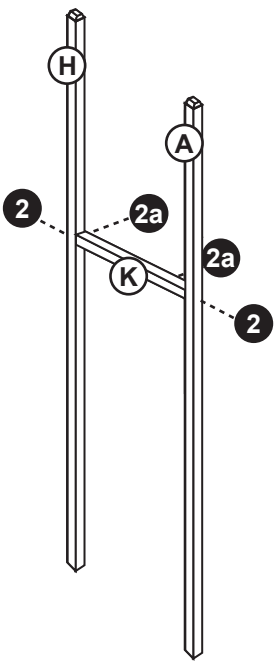

Step 15

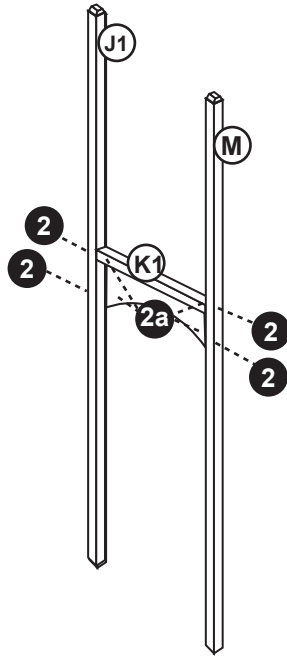

Step 16

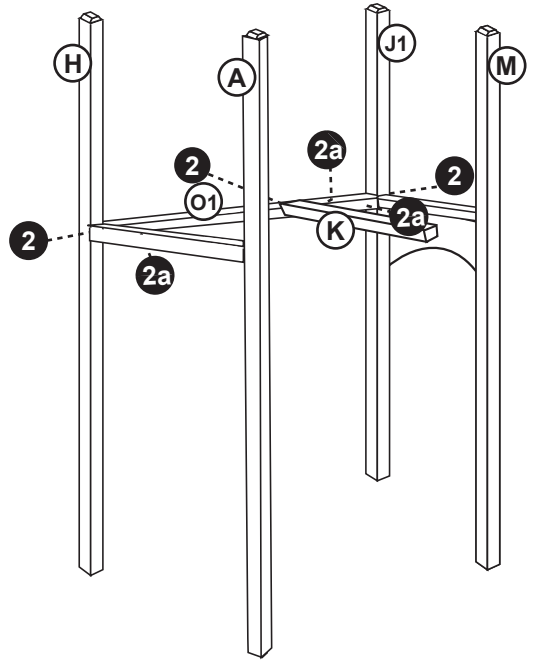

Step 17

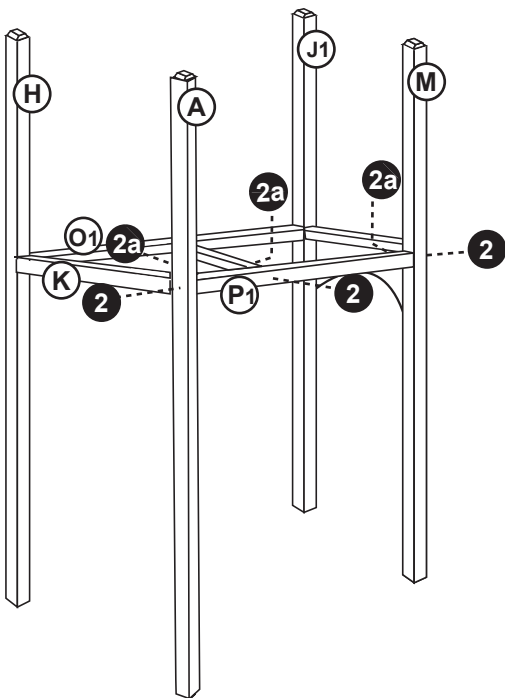

Step 18

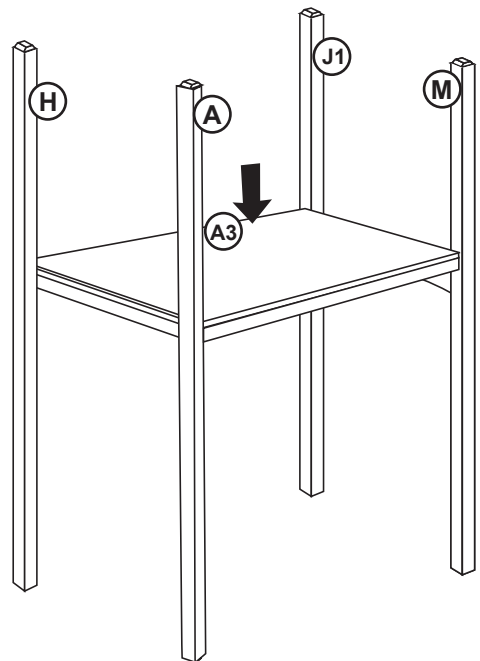

Step 19

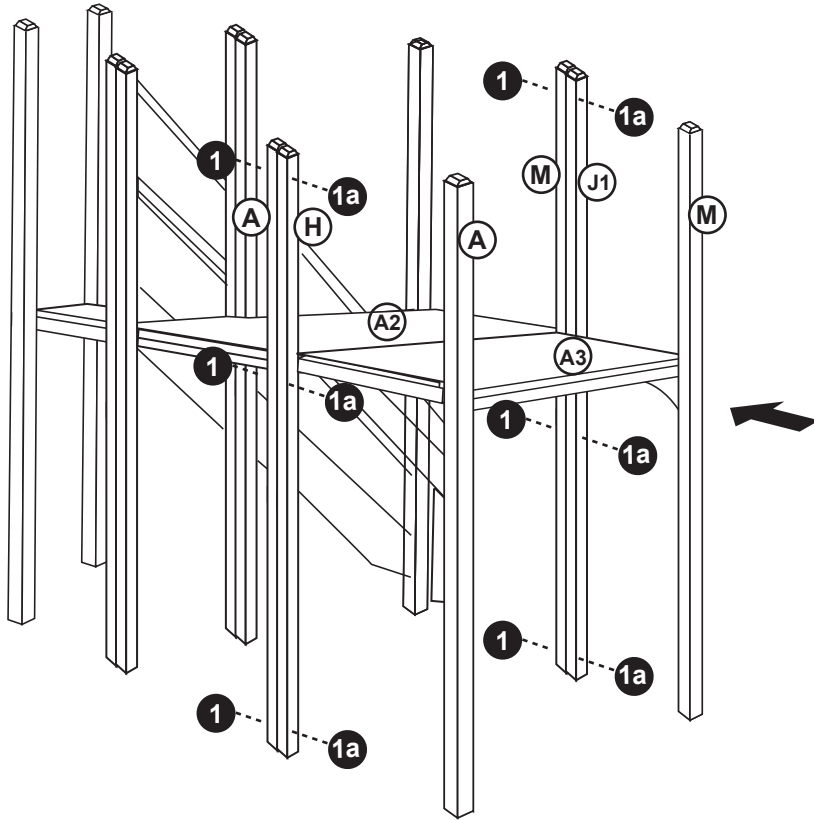

Step 20

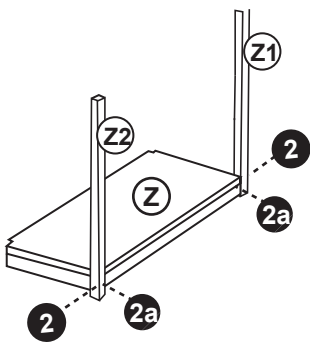

Step 21

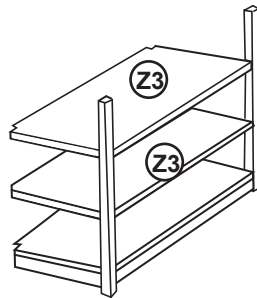

Step 22

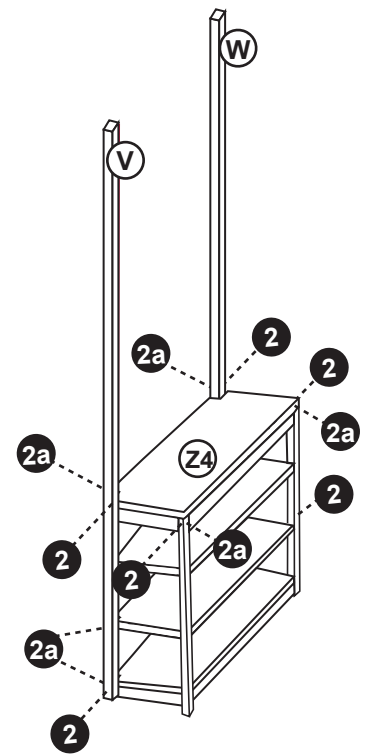

Step 23

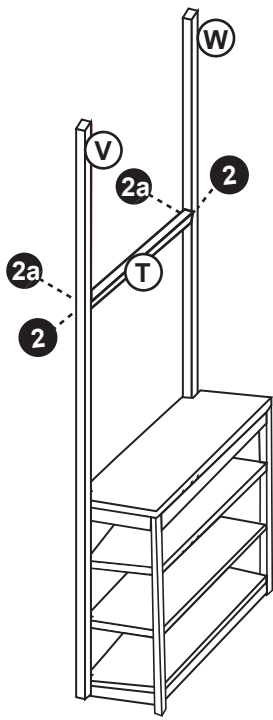

Step 24

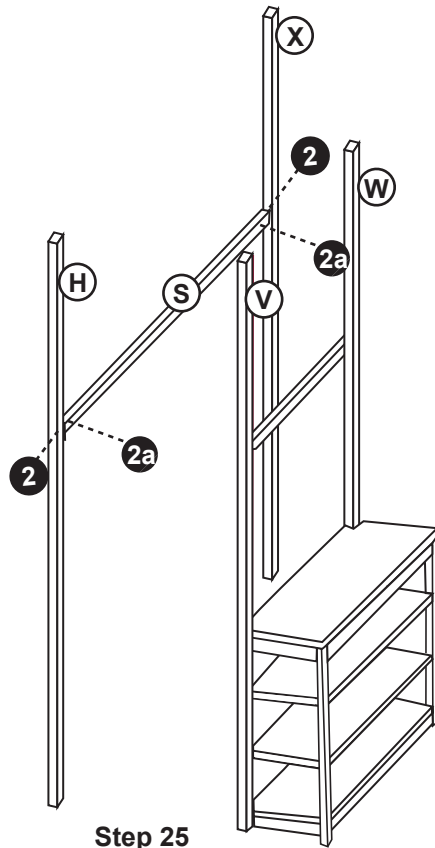

Step 25

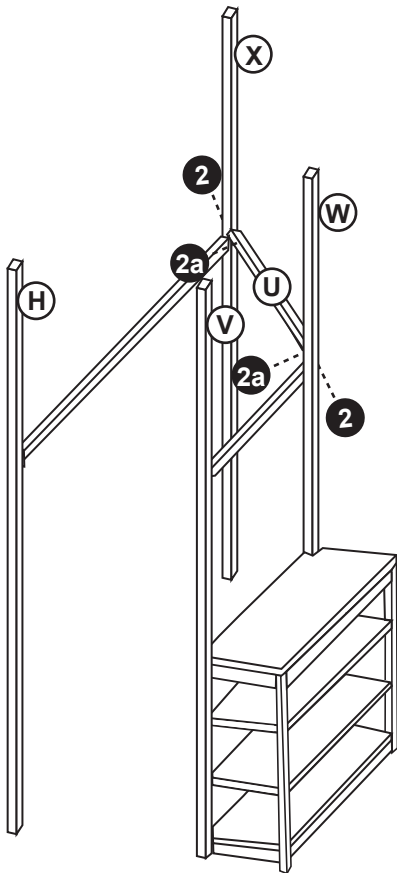

Step 26

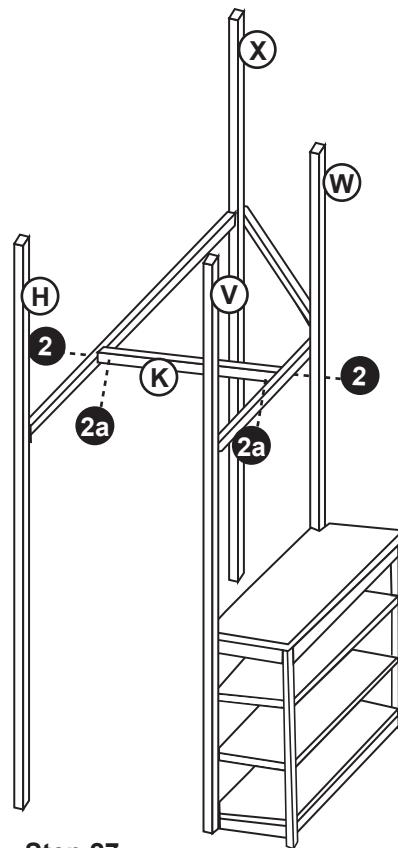

Step 27

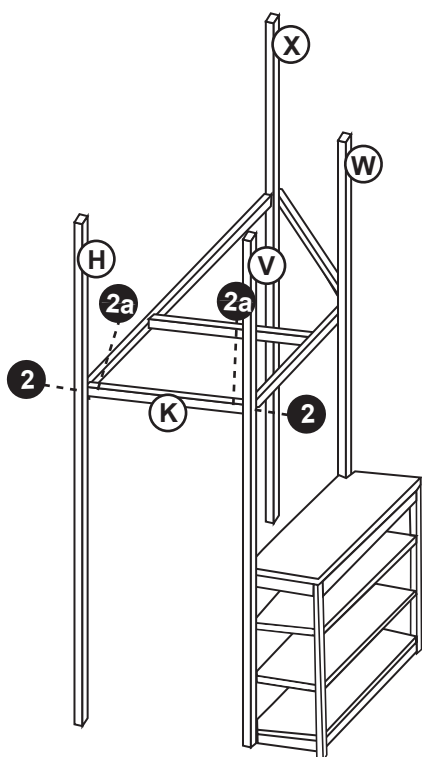

Step 28

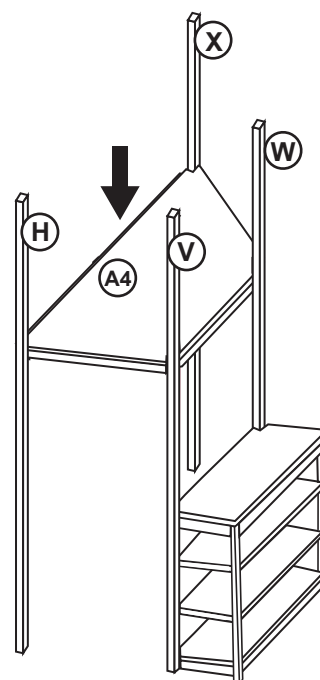

Step 29

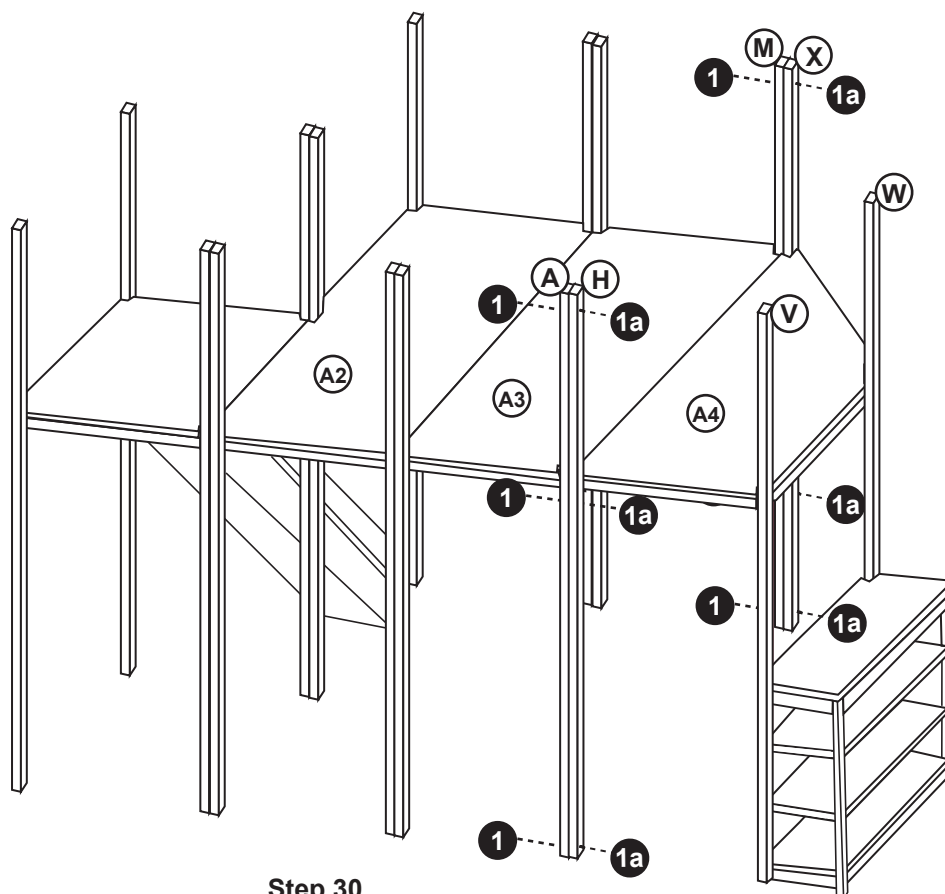

Step 30

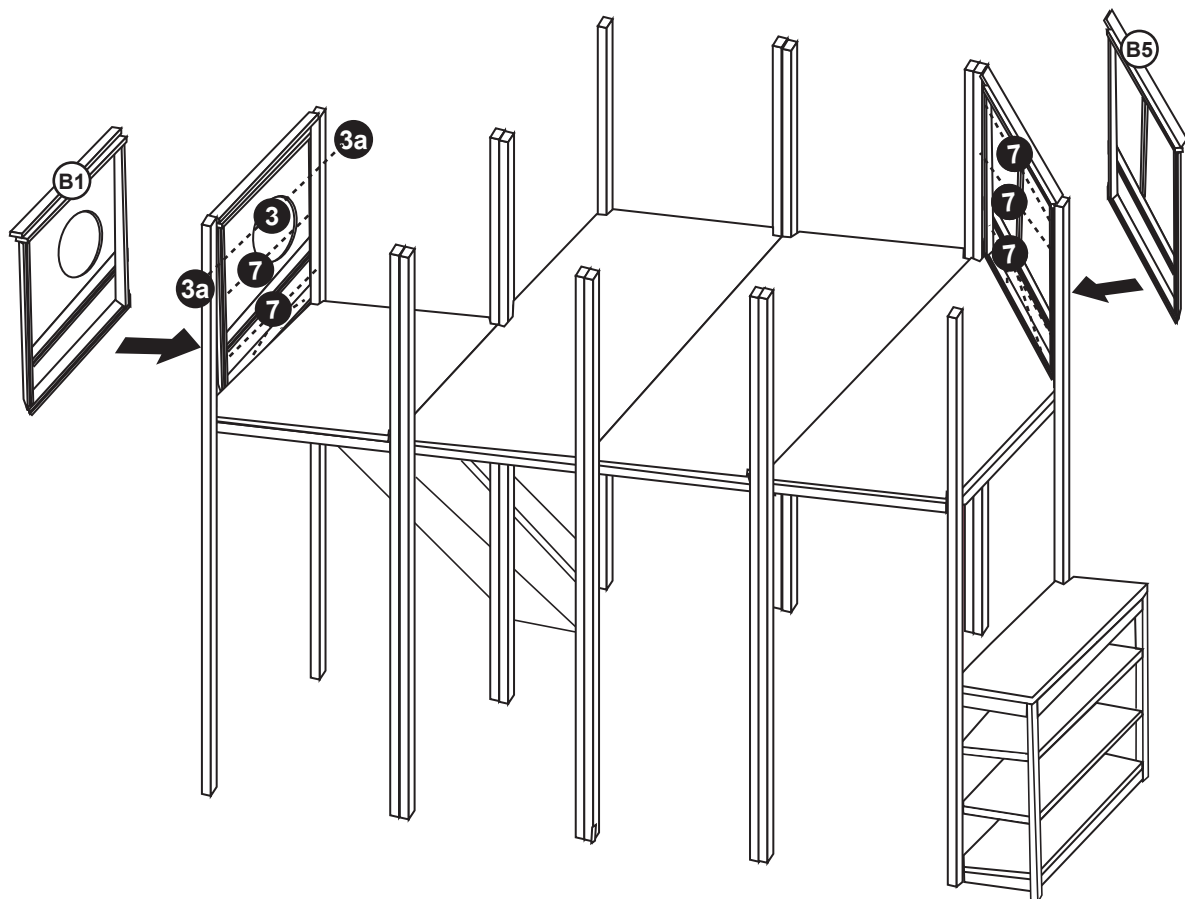

Step 31

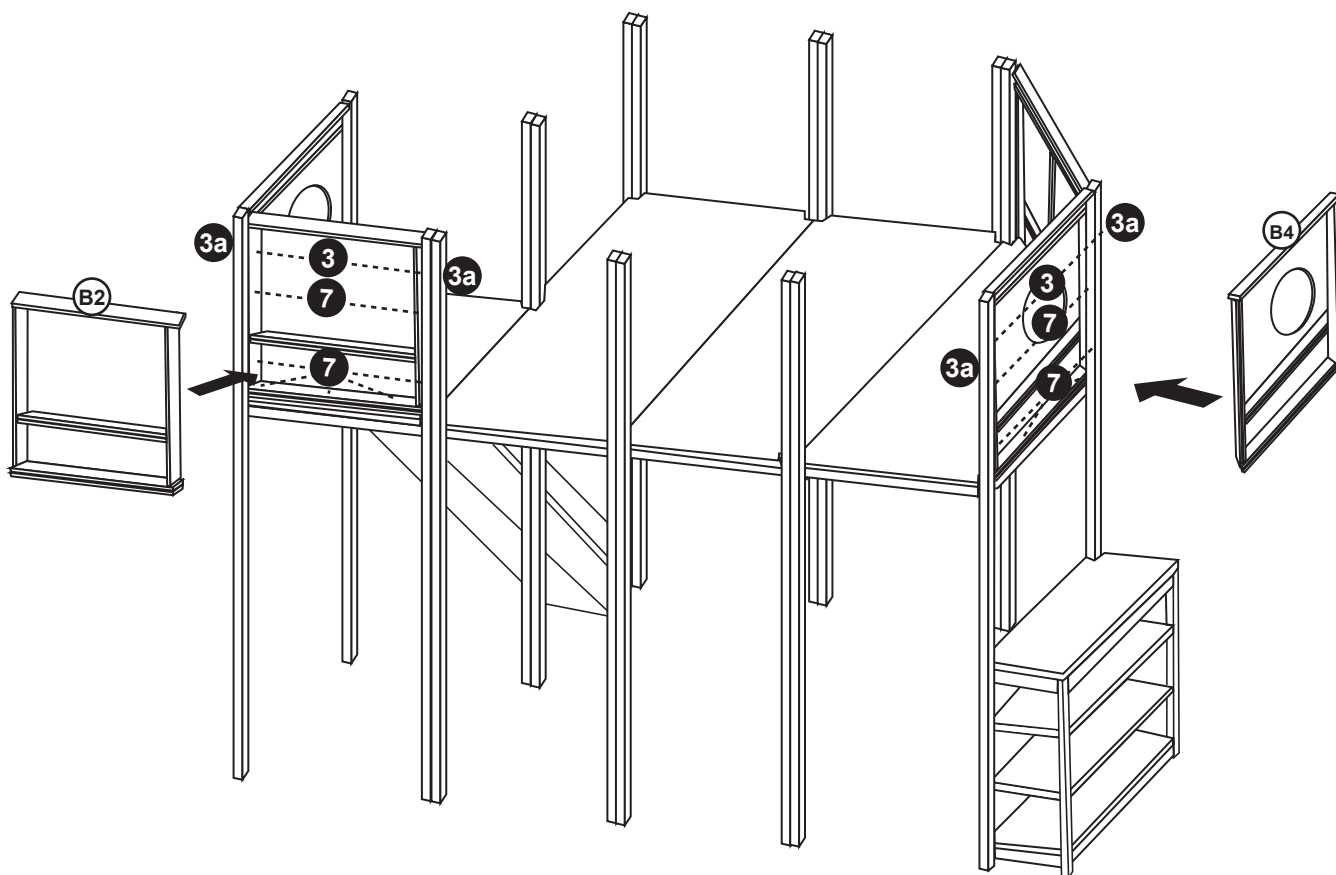

Step 32

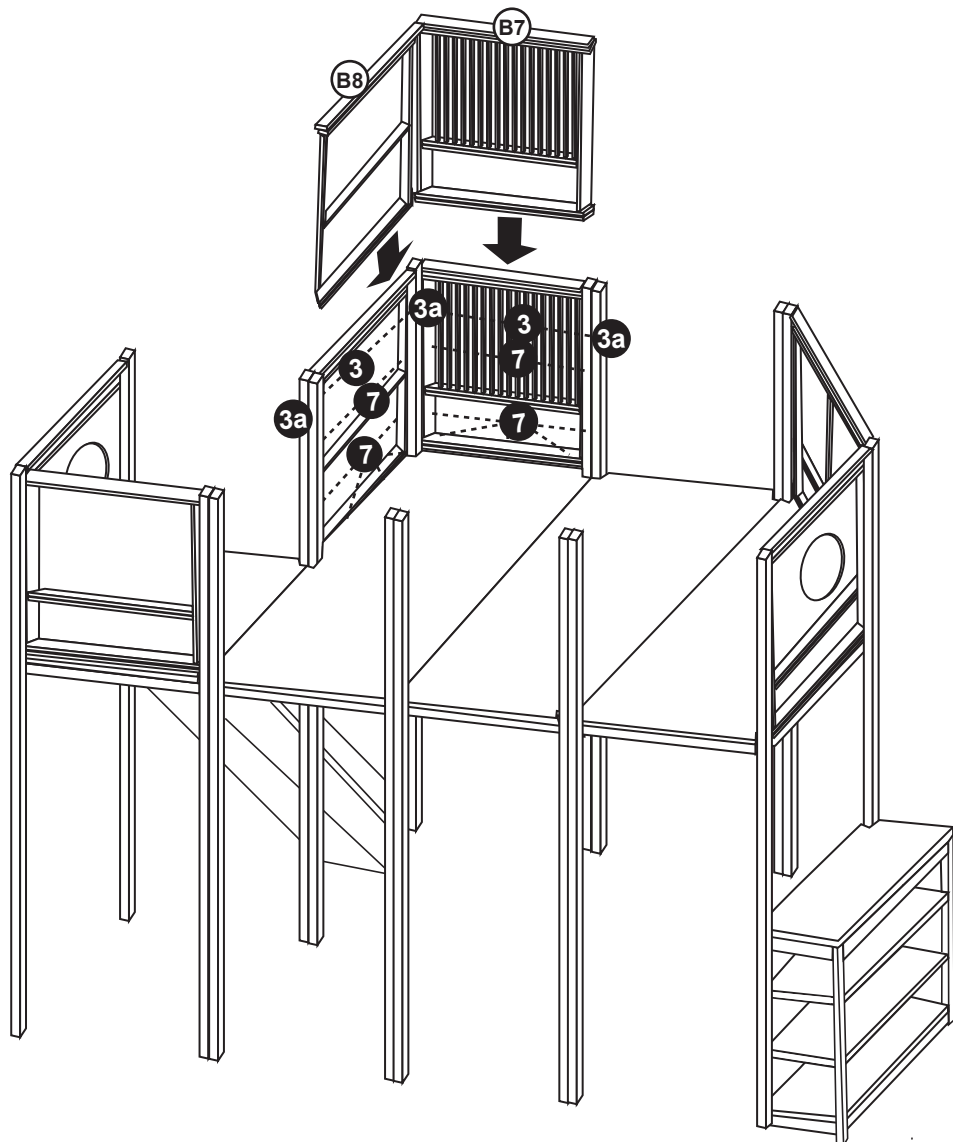

Step 33

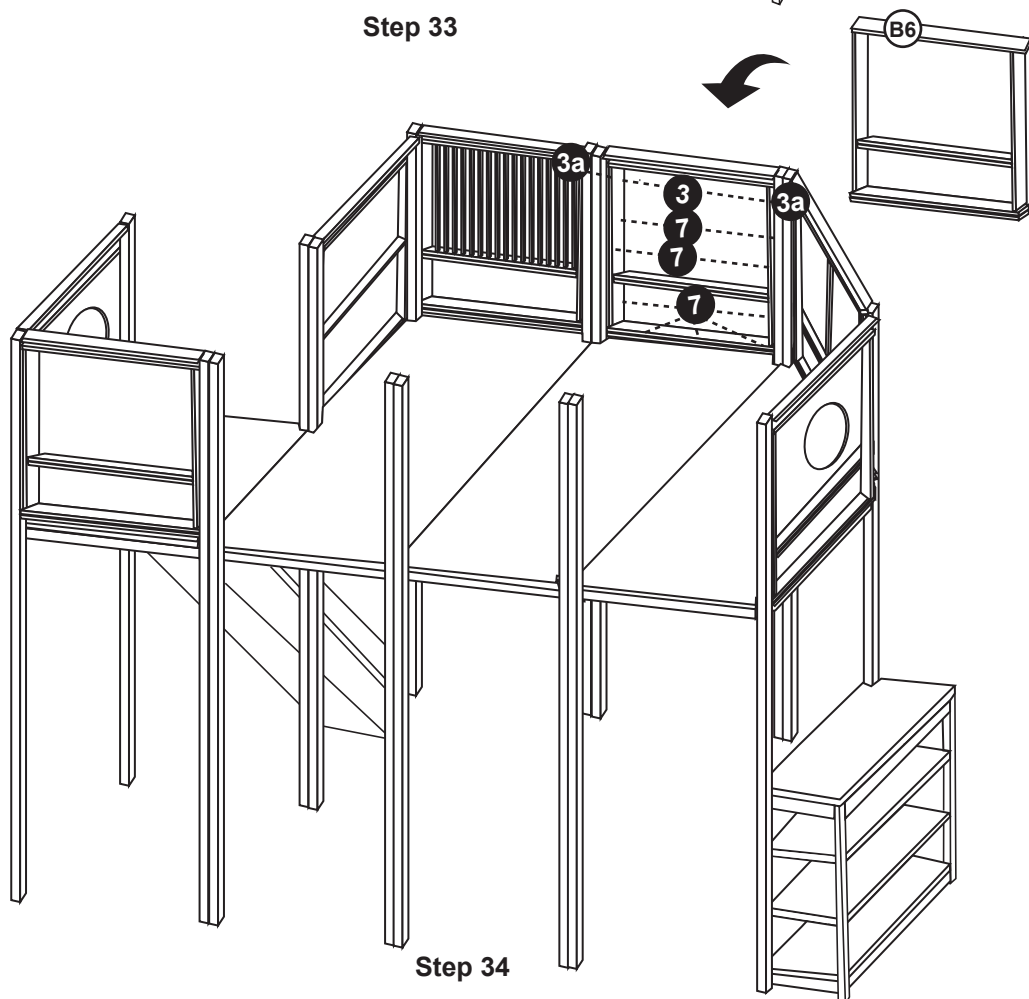

Step 34

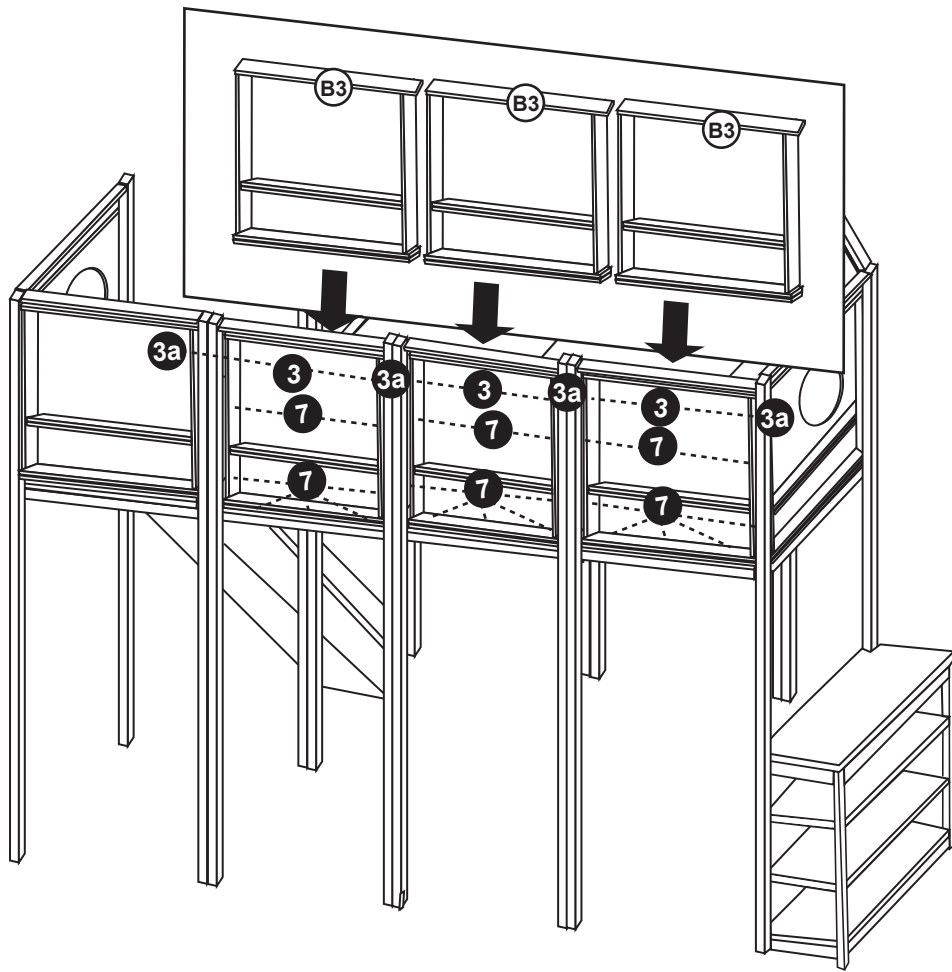

Step 35

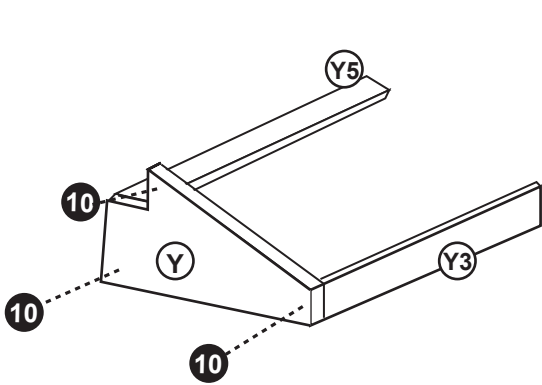

Step 36

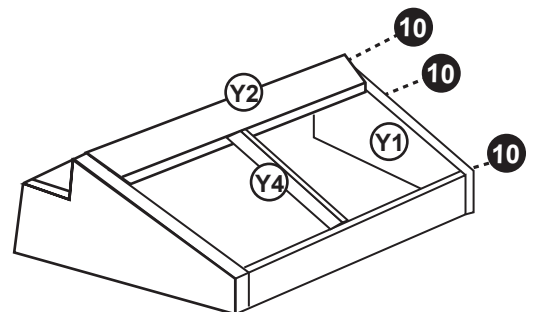

Step 37

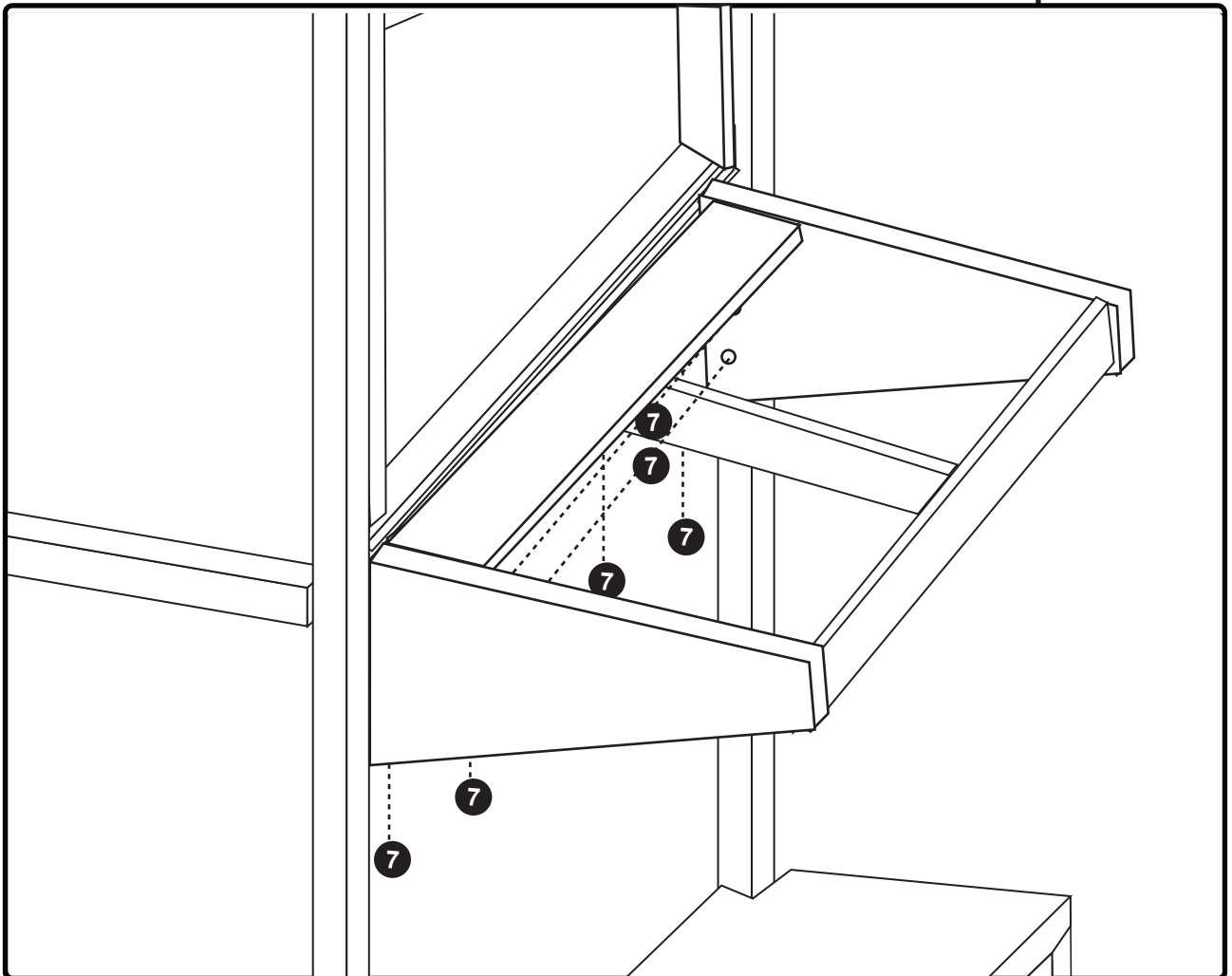
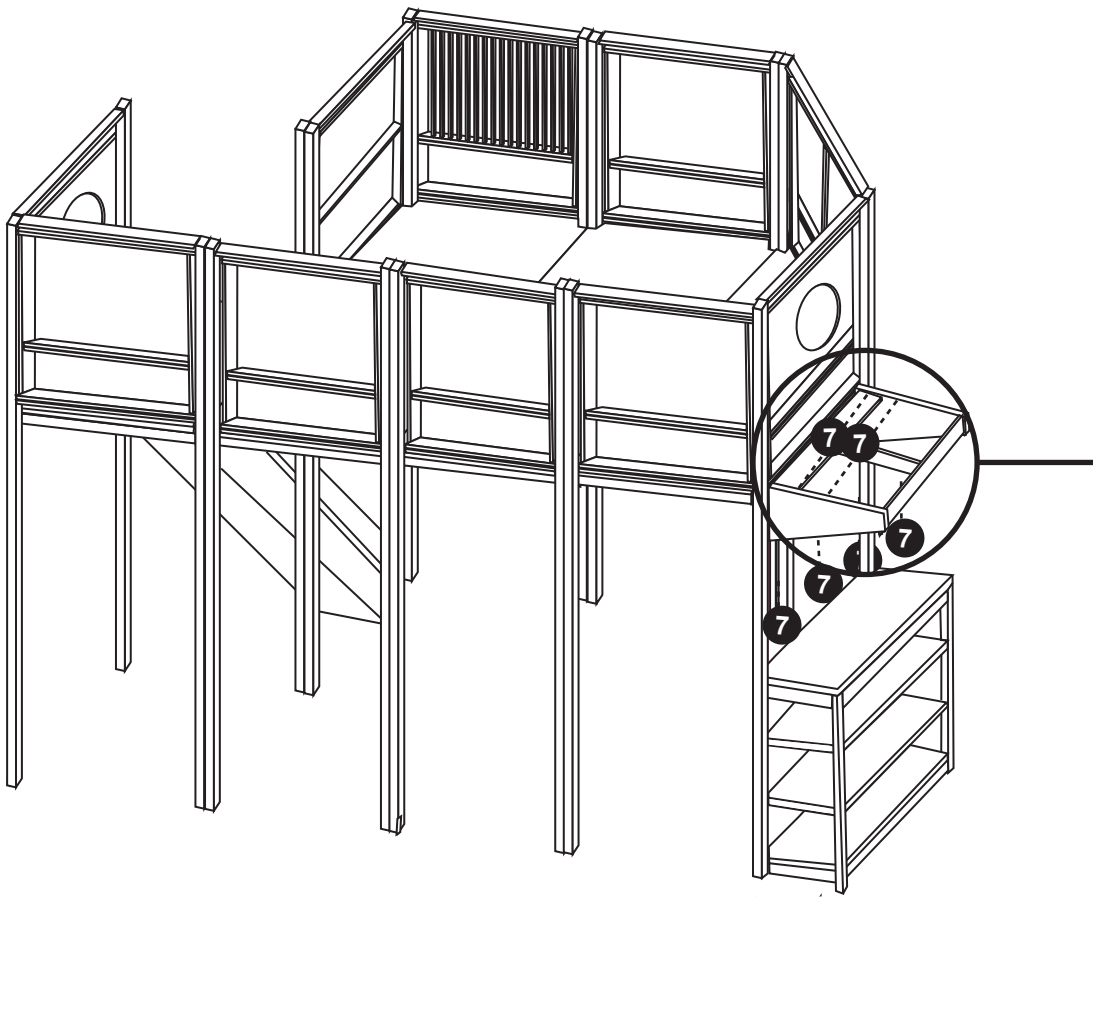

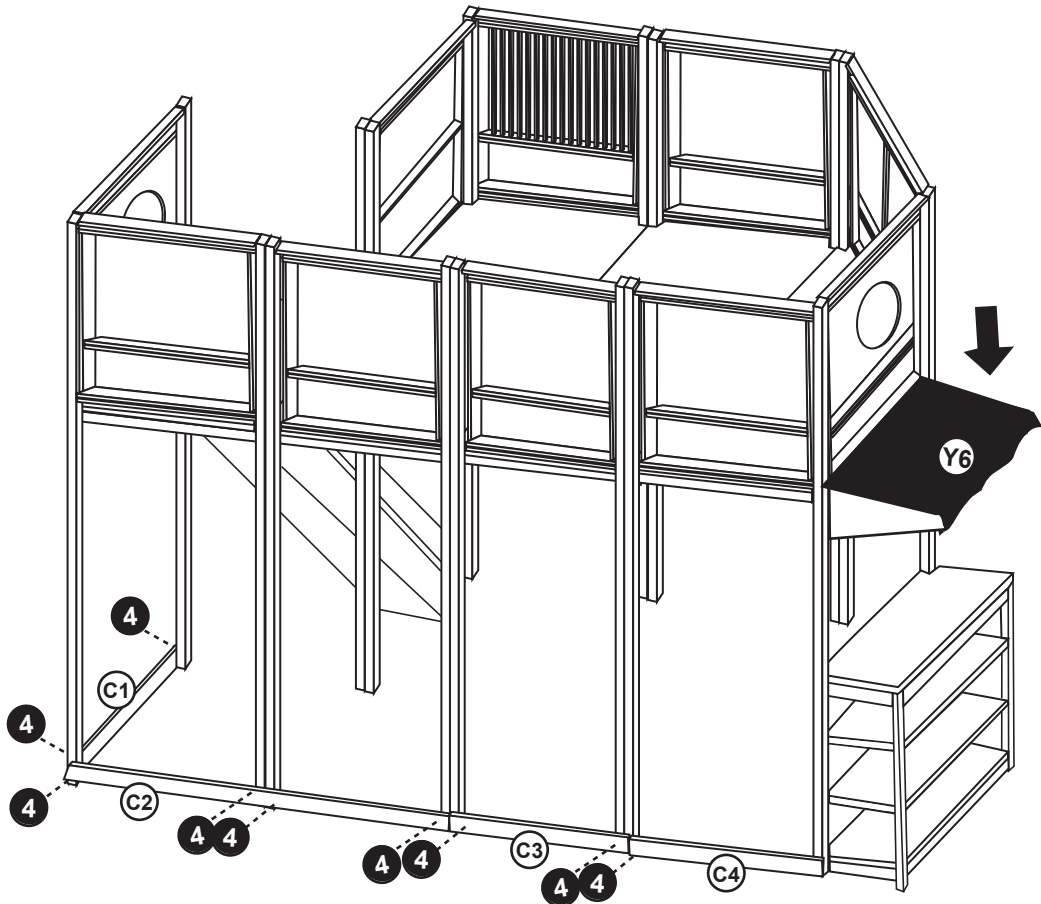

Step 40